

# VALVE-GEARS

FOR

## STEAM-ENGINES

BY

CECIL H. PEABODY

*Professor of Naval Architecture and Marine Engineering  
Massachusetts Institute of Technology*

*SECOND EDITION, REVISED*

TOTAL ISSUE, SEVEN THOUSAND

NEW YORK

JOHN WILEY & SONS

LONDON: CHAPMAN & HALL, LIMITED

1911

**Location of the Reverse-shaft.**—The centre of the reverse-shaft arm  $S$ , Fig. 2, Pl. XX, may now be located as follows: Bisect the line  $mm'$  (shown also on Fig. 7, Pl. XXa) by a line perpendicular to the axis  $XX'$  and on it locate  $N_0$  at a distance from the axis equal to the length of the hanger; draw  $N_0S$  parallel to the axis and make it equal to the length of the reverse-shaft arm. Drill a hole in the drawing-board at  $S$  and connect up the hanger with wooden washers at  $N$  and  $m'$  to give proper clearance so that the model may work freely.

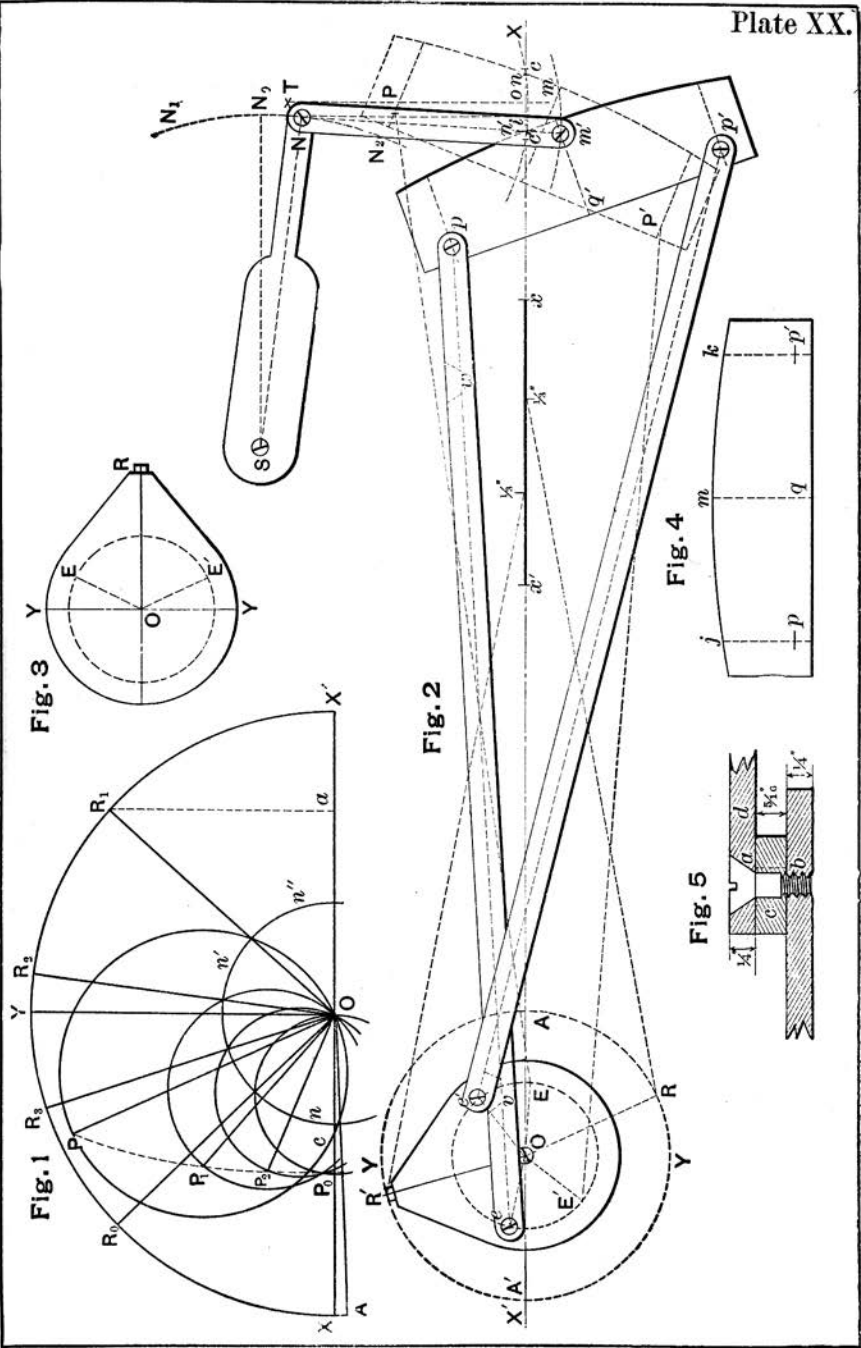

Fig. 1

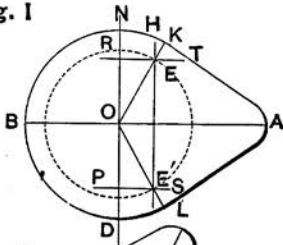

Fig. 2

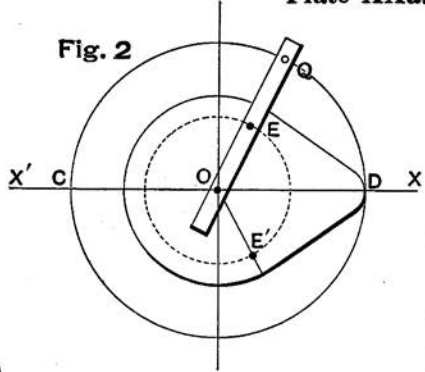

Fig. 3

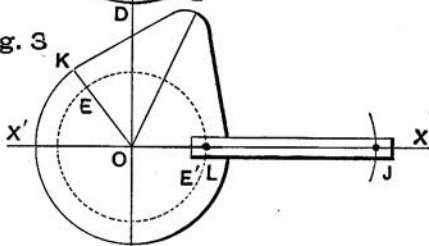

Fig. 4

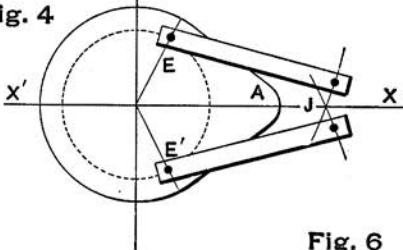

Fig. 5

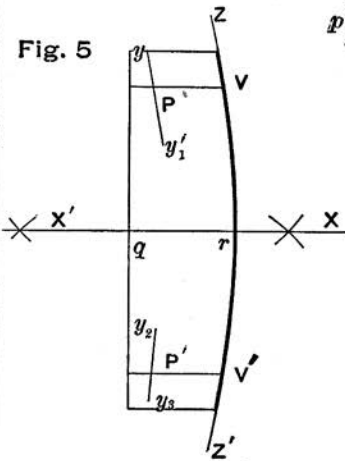

Fig. 6

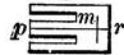

Fig. 7

